

Benjamin

A DIVISION OF
W.R. BENJAMIN
PRODUCTS LIMITED

HEATING PRODUCTS

OWNERS MANUAL

MODEL CC500

IS CERTIFIED TO:

UL 2523-2022

UL 726:1995

CSA B140.7:22
CAN/CSA B366.1-11

Unit/Burner Serial# _____
Purchased From _____
Company Address _____
Name of Installer _____
Installer Telephone # _____
Date Installed _____

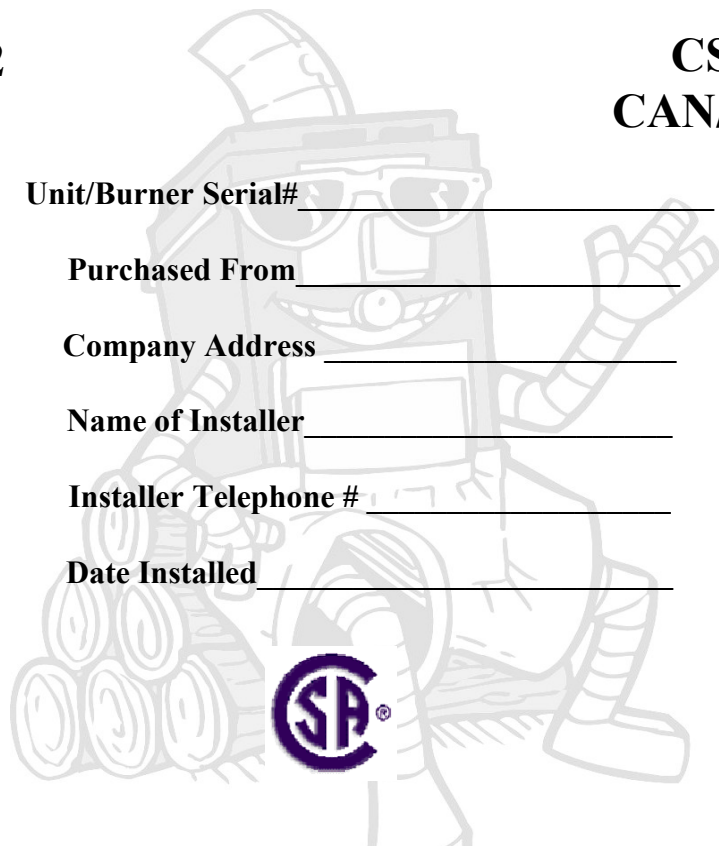

IMPORTANT

This manual must be given to the homeowner. Please read the warranty and return the warranty card to initiate coverage.

We Strongly Recommend The Use Of A Carbon Monoxide Detector When Using Any Product That Consumes Fossil Fuels.

It is the responsibility of the person or company installing this boiler to **verify before the installation** that the boiler certifications shown on this page meet or exceed all local, state and regulatory requirements for installation and use of this boiler. Failure to do so voids all claims and warranties.

November 2025

Aussi disponible en Français.

KEEP THIS MANUAL FOR FUTURE REFERENCE. Follow all instructions carefully for installation, maintenance & operation of the CC500 boiler.

TABLE OF CONTENTS

1. Taking Delivery & Unpacking
Assembly
Chimney and Smoke Pipes
2. Placement of the Unit
Installation Clearances
Fuel Tank Supply
Combustion Air
Very Important homeowner information
3. Aquastat Settings
Oil Burner Installation
Installation of Blocked Flue Sensor
How Much Water to Run in System
4. Electrical
Piping
Adjustments of Damper Motor and Chain (***Diagram***)
5. Operating Instructions (Wood Section)
Normal Operation
Operating Instructions (Oil Section)
To Start the Burner
To Stop the Burner
To Stop the Burner for an Extended Period of Time
6. To Start the Burner after an Extended Shutdown
If the Burner Fails to Operate
When the Burner is in Operation
Special Procedures
Extreme Wood Fire
Flue Fire
7. Electrical Power Failure
To Reset Combustion Controls
General Maintenance Pointers
Burner Maintenance
8. Care of the Boiler When Not in Use
Replacing Hot Water Coils
Cleaning and Servicing Wood Section
Cleaning and Servicing Oil Section
Cleaning and Servicing Oil Section Continued (***Diagram***)
To Clean the Oil Burner
To Clean the Oil Filter
To Clean the Strainer
9. Chimney Connections (***Diagram***)
10. Piping and Wiring Layout (***Diagram***)
11. Electrical (***Diagram***)
12. Domestic Hot Water & Mixing Circulator (***Diagram***)

TAKING DELIVERY AND UNPACKING

Note: The consignee is responsible for ensuring that the packages have arrived in good condition. Examine the packages for damages, if found, note the same on carriers' bill of lading and make a claim to the carrier. Each unit is carefully inspected before leaving our factory.

Package (1) the crated boiler (assembled)

Package (2) the oil burner pack:

1 - Choice of Burner	1 - Damper Motor & Chain	1 - Wiring Harness	1 - Tridicator
1 - ½" Drain Valve	1 - Single Aquastat	1 - Pressure Relief Valve	
1 - N.O. Zone Valve	2 - 24 VA Transformers	3 - Wells	
1 - Triple Aquastat	1 - Triple Aquastat Relay	1 - Blocked Flue Sensor (if applicable)	
2 - Circulator Pumps c/w Flanges			

Please note: The two circulator pumps are required for proper operation of this boiler.

Installation of this unit should be in accordance with the regulations of the authorities having jurisdiction. Reference should be made to: In Canada, CSA B139, "Installation Code for Oil Burning Equipment" for recommended installation practices; **In the United States**, UL 391 "Solid-Fuel and Combination-Fuel Central and Supplementary Furnaces " and UL 726 "Oil Fired Boiler Assemblies".

ASSEMBLY

Benjamin "CC500" boilers are factory assembled. The burner and controls are field mounted using the wiring harness supplied. Other wiring for the thermostats and zone valves are not supplied. (See wiring diagram on page 12)

CHIMNEY AND SMOKE PIPES

(For proper set up, see the diagram on page 10)

The specification of the chimney to be used must comply with the requirement that other than solid-fuel/oil combinations and add-ons, wood burning appliances shall not be connected to a venting system serving an appliance vented by another type of fuel. Connect the boiler to an approved solid fuel factory-built chimney: In **CANADA-CAN/ULC S629** standard for 650°C chimney; In the **UNITED STATES-UL103** Chimneys for Residential Type and Building Heating Appliances, Factory Built or a safe, clean, sound condition, masonry chimney equipped with an approved liner: In **CANADA-CAN/ULC-S635-M90** Standard for Lining Systems for existing masonry or Factory Built Chimneys and Vents; In the **UNITED STATES-UL1777** Chimney Liners (e.g., stainless steel, clay, etc.). The chimney must be equivalent to a minimum of 7" round inside diameter, or 8" round maximum. The chimney must be capable of maintaining a negative updraft at all times and in all conditions. Carefully inspect the chimney for safety and dirt before making connections. Place the boiler as close to the chimney as possible.

The smoke pipe should be blue or black steel, 24 ga. or heavier. Use as few turns as possible between the boiler and the chimney, as each 90° elbow adds 10' of restriction and a 45° elbow adds 5' of restriction. The draft regulator should be 7" diameter and set at -.04 W.C. to open. Install the regulator a minimum of 18" and a maximum of 24" from the boiler breech. Avoid long horizontal runs of smoke pipe. Maintain a minimum of ½" rise per foot of pipe from the boiler to the chimney.

DO NOT run the pipe downhill from the boiler to the chimney. Confirm that the installation clearances are met or exceeded. Secure all smoke pipe joints with three sheet metal screws in each joint.

DO NOT pass the smoke pipes through a wall, floor or ceiling to reach the chimney.

PLACEMENT OF THE UNIT

The CC500 should be as close to the chimney as possible. The CC500 can be installed on a COMBUSTIBLE floor using a non-combustible pad extending 20" front and rear and 6" on each side. The boiler must be properly LEVELED. A 1" (2.5cm) minimum air space must be maintained under the appliance. This can be achieved by using four non-combustible blocks, a minimum of 1" (2.5cm) thick x 4" (10cm) wide x 8" (20cm) long, one to be placed under each corner.

INSTALLATION CLEARANCES (very important)

Front:	48"	One Side:	6"
Rear:	24"	Other Side:	24"
Smoke Pipe:	18"		

FUEL TANK SUPPLY

The fuel supply tank and fuel lines should be installed a minimum of 6' from the boiler and in accordance with codes and standards having jurisdiction in your area. Use flared fittings only.

DO NOT use furl fittings. Protect the oil line from the wood fire door.

COMBUSTION AIR

To achieve satisfactory combustion, an adequate supply of fresh air is required. In confined areas, a grilled opening shall be provided. The minimum total area of a grilled opening is 2 square feet. Where fans are used in the fuel storage area, they should be installed so as not to create negative pressures in the room where the furnace is installed.

VERY IMPORTANT (READ CAREFULLY)

1. The furnace must be installed by a qualified technician currently active in the heating trade & meet or exceed all local or national codes.
2. DO NOT TAMPER WITH THE UNIT OR CONTROLS - CALL A QUALIFIED SERVICE TECHNICIAN.
3. Use No.2 furnace oil only. DO NOT USE GASOLINE, CRANKCASE DRAININGS, OR ANY OIL CONTAINING GASOLINE. Use of other fuels could damage the unit or present a serious safety Hazard.
4. DO NOT use furnace oil in the solid fuel section.
5. DO NOT BURN GARBAGE OR PAPER IN THE UNIT OR LEAVE COMBUSTIBLE MATERIALS AROUND THE UNIT.
6. Know the location of the emergency disconnect switch for the unit.
7. Contact a qualified service technician before remodeling, for annual service/maintenance, before extended periods of shutdown and before start-up.
8. DO NOT stack items on or around the boiler - check required clearances on this page.
9. DO NOT store flammable materials in the vicinity of the furnace.
10. DO NOT start this unit until all components are securely in place.
11. DO NOT start the wood or oil section until the boiler is properly filled with water (damage will result voiding the warranty).

*Ensure that the water pressure reducing valve is working properly (set at 12 p.s.i.). Too high a pressure will damage the boiler (voiding the warranty).

*Care must be taken to ensure that the boiler will not be exposed to thermal shock which can be caused when the system return water temperature is more than 40°F below the system supply water temperature.

ELECTRONIC AQUASTAT SETTINGS

As shown on the wiring diagram on page 12.

Recommendation If Using the Domestic Hot Water Coils in the Boiler

When the wood section of your boiler is not in use for an extended period of time, change the electronic oil aquastat setting to a low limit of 180°F and a high limit, not to exceed 200°F. This is to better assist in the heating of the domestic hot water.

CAUTION: Be sure to return the settings to the normal (low 150°F & high 170°F) before starting your wood section again.

Setting Electronic Aquastat

To set Electronic Aquastat press the Up, Down, and I buttons simultaneously for three seconds. Press the I button until the feature to be set is displayed:

* **HL-High limit LL-Low Limit, Ldf-Low limit differential,**

Hdf-High limit differential, F-C -- °F or °C

Then press the up and/or down buttons to move the set point to the desired value. After 60 seconds without any button inputs, the controller automatically returns to run mode.

OIL BURNER INSTALLATION

Proper nozzles and settings for (Use No. 2 Furnace Oil):

Burner	Nozzle	Input	Pump Pressure	Turbulator	Initial Air	BTU/Hour	Insertion
Beckett AFG	Delevan 0.75 x 80°B	0.89 gph	140 psi		38625	106600	4.00"
Beckett AFG	Delevan 0.85 x 80°B	1.01 gph	140 psi		38626	118700	4.00"
Riello F5	Delevan 0.75 x 80°B	0.90 gph	145 psi	1.5	3.5	107000	4-1/8"
Riello F5	Delevan 0.85 x 80°B	1.02 gph	145 psi	3.25	3.75	120700	4-1/8"

The oil burner is mounted on the 3 studs provided on the lower front combustion chamber access panel. Extreme care should be taken when mounting the burner, not to damage the molded combustion chamber.

The air opening on the oil burner should be adjusted to obtain a #0 Bacharach smoke spot. At this point, maximum fuel efficiency is obtained. Having obtained the proper smoke spot, the following should be observed: The CO in the flue should be between 10 and 13.5%. Draft setting - not to exceed -.04" W.C. (the draft is adjustable by means of adjusting the screw/wheel located on the front of the barometric draft regulator).

INSTALLATION OF BLOCKED FLUE SENSOR (If Applicable)

Install the Field Controls WMO-1 in the oil flue pipe as given in the sensor installation instructions.

HOW MUCH WATER TO RUN IN THE SYSTEM

For hot water heating, beginning with the lowest radiator, open the vent and allow air to escape, closing the vent when the water begins to flow from it. Repeat this on all other radiators, continuing to the second and then higher floors. (Radiators equipped with automatic air vent valves do not require venting by hand except to speed up initial filling of system). Check the water level regularly for loss due to leaks or evaporation. All systems must be provided with an expansion tank and relief valve. Water should be fed to the system by means of an automatic fill valve available for that purpose and backflow prevention must be used.

The relief valve should be opened occasionally to make sure it is operative. The relief valve should open when the pressure indicated on the combination gauge exceeds thirty pounds. If this pressure is exceeded before the relief valve opens, shut off the fill valve and drain the water from the system until the pressure is reduced below thirty pounds and have the valve repaired or replaced immediately. A water logged air cushion tank is indicated by rapid increase in pressure with only slight increase in temperature, or frequent escape of water from the relief valve.

CHECK THE SAFETY RELIEF VALVE ON THE BOILER MONTHLY. Test the safety relief valve by momentarily pulling the lever to observe free escape of hot water.

NOTE: Drain pipes from the safety relief and the boiler drain valves shall be piped to a safe drain.

ELECTRICAL

Electrical installations must conform to all local and national codes and standards as their jurisdiction may apply. See page 12.

PIPING

Piping must conform to all local and national codes and standards as their jurisdiction may apply. See pages 11 & 13. The dump zone should be your existing largest zone (that has all piping above the boiler.-e.g. Living room or master bedroom). With a home built on slab or heating with an under floor radiant system, a separate zone should be added above the boiler. This zone would be of adequate size to dissipate at least 15,000 btu/hr. The piping must be a minimum of $\frac{3}{4}$ " (18 mm) diameter and able to withstand a minimum temperature of 225°F (107°C). This loop shall be such that it can only be made inoperative by a deliberate manual action. Please ensure that the pressure relief valve and the boiler drain valve are piped to a safe drain (water discharging from either could be extremely hot and dangerous).

All piping will be such that excessive pressure will not be developed in any portion of the boiler or system.

NOTE: It is important to install a throttle flow valve in order to control the flow of water through the domestic water system. Set the valve to regulate the flow to achieve the required temperature.

ADJUSTMENTS OF DAMPER MOTOR AND CHAIN

The damper chain should be adjusted when the damper door is in the down position. In this position the chain should be adjusted so there is a small amount of slack.

The amount of lift or opening of the damper door is adjusted by moving the two pinch nuts on the stove bolt thread closer or further away from the lift strap. The damper should be set at $\frac{3}{4}$ " to 1" opening. After proper adjustment of the draft chain and damper door the thermostat and aquastat will keep the fire within safe limits.

CAUTION: This setting should not be altered for increased firing, for any reason.

NOTE:

- DO NOT use automatic stoking or sawdust fueling on this boiler.
- DO keep the boiler area clean and clear of all debris at all times.
- DO NOT burn gasoline, naphtha, kerosene, engine oil, (fuel oil in the wood section) or other volatile, creosote soaked wood or drift wood. (Damage to your boiler will result and void the warranty.)
- This boiler will burn most wood fuels. However, it is recommended that dry, untreated, natural hardwood be used as much as possible. It affords cleaner more efficient burning with less soot, creosote and ash build-up, as well as less frequent firing intervals.
- Store wood in neat, well supported piles at least 4 feet from the charging door.
- To prevent injury, DO NOT allow anyone who is unfamiliar with the operation of the boiler to attend it.

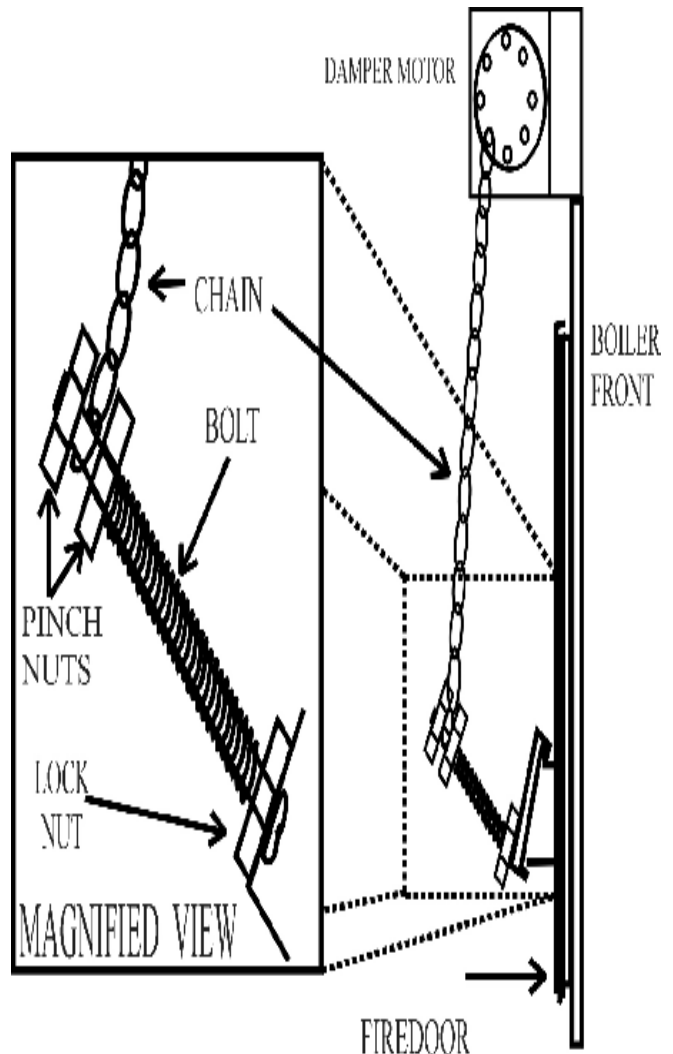

OPERATING INSTRUCTIONS (WOOD SECTION)

Proper draft in the wood section will not be achieved until 2" to 3" of ash is built up in the firebox. This can be readily accomplished using softwoods, which creates ash quickly or use clean sand (with "no salt" in it).

Caution: DO NOT fire this boiler until all requirements are complete and the operating instructions are fully understood.

NOTE: Your oil burner may start even when the wood fire is on. This is caused by large amounts of heat being taken from the unit. This is normal, as the oil burner will boost the water temperature around the coils ensuring ample domestic hot water.

NORMAL OPERATION

1. The oil burner will start if the system temperature is below the setting on the oil control aquastat.
2. The damper motor opens the damper door if the temperature of the boiler falls below 170°F.
3. The thermostats control the opening of zone valves. The primary (House) circulator runs when the zone thermostats call for heat.
4. Should an extreme fire cause the high limit switch to close, the damper motor will close the damper door, the normally open (N.O.) zone valve will open and the circulator will start. The oil burner will not be able to start

Note: Establish a routine for the storage of fuel, care of the appliance, and firing techniques. Check daily for creosote build up, until experience shows how often cleaning is necessary. Be aware that the hotter the fire, the less creosote is deposited and weekly cleaning may be necessary in mild weather even though monthly cleaning may be enough in the coldest months. Have a clearly understood plan to handle a flue fire.

OPERATING INSTRUCTIONS (OIL SECTION) TO START THE BURNER

See that all valves in the oil lines are open.

1. With the main cutout switch for the oil burner electrical circuit in the "OFF" position, set the thermostat at a point above room temperature.
2. Set the electric switch to the "ON" position. If the burner fails to start instantly, set the master switch to the "OFF" position and call a qualified service technician.
3. If the burner starts to operate normally leave the switch "ON" and reset the thermostat to the desired temperature.

Never start the burner under the following conditions:

1. WHEN EXCESS OIL HAS ACCUMULATED.
2. WHEN OIL VAPORS ARE PRESENT.
3. WHEN THE COMBUSTION AREA IS VERY HOT.
4. WHEN THE SIGHT PORT DOOR COVER IS NOT SECURE.
5. When the smoke pipe is removed or blocked.
6. Any situation that would lead to an unsafe condition.

Never push the reset on the burner more than once; contact a heating technician.

TO STOP THE BURNER

1. Set the main cutout to the "OFF" position.
2. Set the thermostat as far below room temperature as possible.

TO STOP THE BURNER FOR AN EXTENDED PERIOD OF TIME

1. The main cutout switch should be set to the "OFF" position.
2. ALL OIL VALVES SHOULD BE CLOSED.
3. The burner should be covered to protect it from dust and dampness.

TO START THE BURNER AFTER AN EXTENDED SHUTDOWN

1. The strainer in the pump should be cleaned, and if a filter is installed in the oil line, it should be cleaned and the filter cartridge replaced.
2. The fan and the blower housing should be cleaned.
3. The ignition points should be checked and the nozzle cleaned and replaced.
4. Oil the motor.
5. Start the burner by following the instructions under the paragraph, "TO START THE BURNER".
7. It is recommended that a qualified service technician be called to clean the unit and burner and make sure that the burner is operating properly. The installer should identify the emergency shut off switch and valves.

IF THE BURNER FAILS TO OPERATE

Call a qualified service technician. The trouble may be due to:

1. Blown fuses in the electrical circuit.
2. The thermostat may be set below room temperature.
3. Combustion control may require "resetting" (**DO NOT** press the reset more than once).
4. The oil valve may be closed.
5. The oil supply may be too low.
6. The blocked flue sensor may be tripped.(If installed)

WHEN THE BURNER IS IN OPERATION

1. When cleaning the boiler room or utility room, always stop the burner to reduce the amount of dust and lint drawn into the burner.
2. The electric ignition system and all controls should be checked periodically for reliability of operation and adjusted if necessary.

SPECIAL PROCEDURES

EXTREME WOOD FIRE (Due to improper operation)

1. Disconnect the damper chain to prevent the damper door from opening.
2. Block the over-fire draft slot in the door.
3. Increase all thermostats to maximum.
4. Excessive heat may cause safety relief valve to open. (*Ensure it is piped to a safe drain.*)
5. **DO NOT** shut power off.

FLUE FIRE

1. Call the Fire Department.
2. Prepare to evacuate the house.
3. Shut off the main power switch to the boiler.
4. Diminish the fire in the boiler by closing all combustion air openings.
5. **DO NOT** remove the flue pipes until the fire is completely out.
6. Have the chimney inspected and repaired if necessary before reusing the unit.

ELECTRICAL POWER FAILURE

NOTE: DO NOT operate your appliance, unless your total heating system has been designed and installed to operate properly without electricity.

1. Maintain ½ the normal fire load.
2. The air damper must be manually operated. (**DO NOT** prop or tie open.)
3. Fire the boiler carefully. Remember you are now on gravity circulation only. It is necessary to manually open the zone valve (if used). Each system is different, extreme care must be used until a safe rate of firing is known for your system, in a no power situation.

TO RESET COMBUSTION CONTROLS

The reset control consists of an electrical relay operating in conjunction with a flame detector mounted on the oil pipe of the burner assembly of the burner. When for any reason the burner fails to ignite promptly, the control will stop the burner. After being shut off in this manner, the burner cannot again be started until the control is "RESET". The burner mounted relay is attached to the burner housing and is reset by pushing the "RESET" button and then releasing. **DO NOT press the reset button more than once. Call a qualified service technician.**

The blocked flue sensor, if installed, is designed to shut off the burner in the event that the flue has become blocked. When this has happened, the burner cannot be started again until the sensor has been reset. Pushing in the red button, which is accessed through the hole in the front of the sensor, resets the sensor. **Only try this once and then call a qualified service technician.**

GENERAL MAINTENANCE POINTERS

1. Keep the flues in the boiler clean. Because soot is a nonconductor of heat, a dirty boiler requires more fuel to heat a house than a clean one.
2. The smoke pipe should be taken off as necessary and thoroughly cleaned of all soot.
3. It is recommended to periodically check the nuts holding the coil plate on the main boiler back and tighten if necessary.

BURNER MAINTENANCE

Use the following checklist when performing annual burner service. To be performed by a qualified service technician.

- Replace the oil supply line filter. Thoroughly clean the filter body before installing a new cartridge.
- Remove and clean the pump strainer (if applicable).
- Replace the nozzle with an equivalent nozzle.
- Clean and inspect the electrodes for damage, replacing any that are cracked or chipped.
- Check electrode tip settings.
- Inspect the transformer contacts.
- Clean the cad cell.
- Oil the motor (if applicable) a good grade of medium detergent-free automobile engine oil should be used. Twice each year one table spoon of oil should be poured slowly into the oil cup
- Clean the blower wheel, air inlet, and retention head and throttle plate of any lint or any foreign material.
- Check all wiring for secure connections or insulation breaks.
- Check the pump pressure.
- Adjust the burner to proper settings on page 3 "using proper instruments".

CARE OF THE BOILER WHEN NOT IN USE

When the boiler is out of service for an extended period of time, carefully and thoroughly clean the smoke pipe, chimney, firebox and any part which has been in contact with hot gases. This is extremely important as rusting and corrosion occur when the boiler is idle.

REPLACING THE HOT WATER COILS

The rear casing panel of your boiler must be removed to gain access to the hot water coils mounting plates. It is necessary to remove the smoke pipes before removing the rear panel. (ENSURE THAT NO FIRE IS PRESENT AND POWER DISCONNECTS ARE OFF BEFORE REMOVING SMOKE PIPES). The water must be drained from the boiler before removing coil mounting plates, ensure the water supply to the coils is off before removing. Two openings are provided in your boiler for hot water coils

CLEANING AND SERVICING (WOOD SECTION)

It is necessary to remove ash and occasionally brush the inner surfaces with a wire brush and check the smoke pipe for ash or creosote as necessary. Leave 2" of ash in the wood firebox when cleaning, to aid in combustion.

IMPORTANT: Fire can be caused by improper storage of ashes containing dormant hot coals. Store ashes in a tightly covered metal container. **DO NOT** place other waste in this container.

VERY IMPORTANT: Replace all damaged or worn gaskets before reassembling. Fire door gaskets and seals must be maintained in good condition for safe operation.

CLEANING AND SERVICING (OIL SECTION)

IT IS HIGHLY RECOMMENDED THAT A QUALIFIED SERVICE TECHNICIAN (REGULARLY ENGAGED IN THE HEATING TRADE) BE EMPLOYED TO DO THE CLEANING AND SERVICING.

Your Benjamin "CC500" boiler is equipped with one of the most modern molded combustion chambers available. However, it is easily damaged and care must be taken handling it. To remove the chamber, (*see diagram right*) first remove the oil burner (8) from the three mounting studs, then remove the combustion chamber access panel (6) by means of four nuts. Use extreme care when removing the panel, as the combustion chamber is mounted on the rear of the panel. The combustion chamber is removed by loosening the bolts on the metal clamping rings (13), releasing the combustion chamber. The new combustion chamber is installed by reversing the order of removal. (INSPECT ALL INNER SURFACES AND BAFFLES, CLEAN BEFORE REPLACING.)

At the end of the heating season, thoroughly clean the inner surfaces of the boiler, the flue passages, flue pipe and chimneys. It is recommended that a properly equipped service technician do this job. Once yearly or as necessary, remove the oil burner by means of three nuts. Inspect and service the burner. Remove the oil chamber access panel by means of four nuts. It may be necessary to remove the combustion baffles 10 and 14 by means of 2 screws (12). Clean the inner surfaces with a wire brush. (**DO NOT USE A WIRE BRUSH ON THE COMBUSTION CHAMBER, DAMAGE WILL RESULT.**) Also inspect the smoke pipe and flue for ash or creosote buildup and clean if necessary.

OIL BURNER

The oil burner should be removed at least once each heating season, cleaned and serviced. Also inspect and clean any accumulated soot and debris from the combustion chamber and transfer duct. Inspect and replace the burner gasket if necessary. To be performed by a Qualified Service Technician.

OIL FILTER

The cartridge should be replaced at least once a year. The filter body should be thoroughly cleaned before installing a new cartridge.

TO CLEAN THE STRAINER

1. Oil valves between the tank and the burner should be closed.
2. The strainer cover should be removed.
3. The strainer basket should be taken out and washed with kerosene.
4. The strainer basket and covers should be reassembled with gaskets that are clean and in good condition.

CHIMNEY CONNECTIONS FOR THE CC500 BOILER

**A LINED MASONRY
CHIMNEY APPROVED
FOR BURNING SOLID
FUEL SAFELY.**

SMOKE PIPE MUST
HAVE A MIN. 1/2" PER
FOOT RISE FROM THE
BOILER TO THE FLUE.

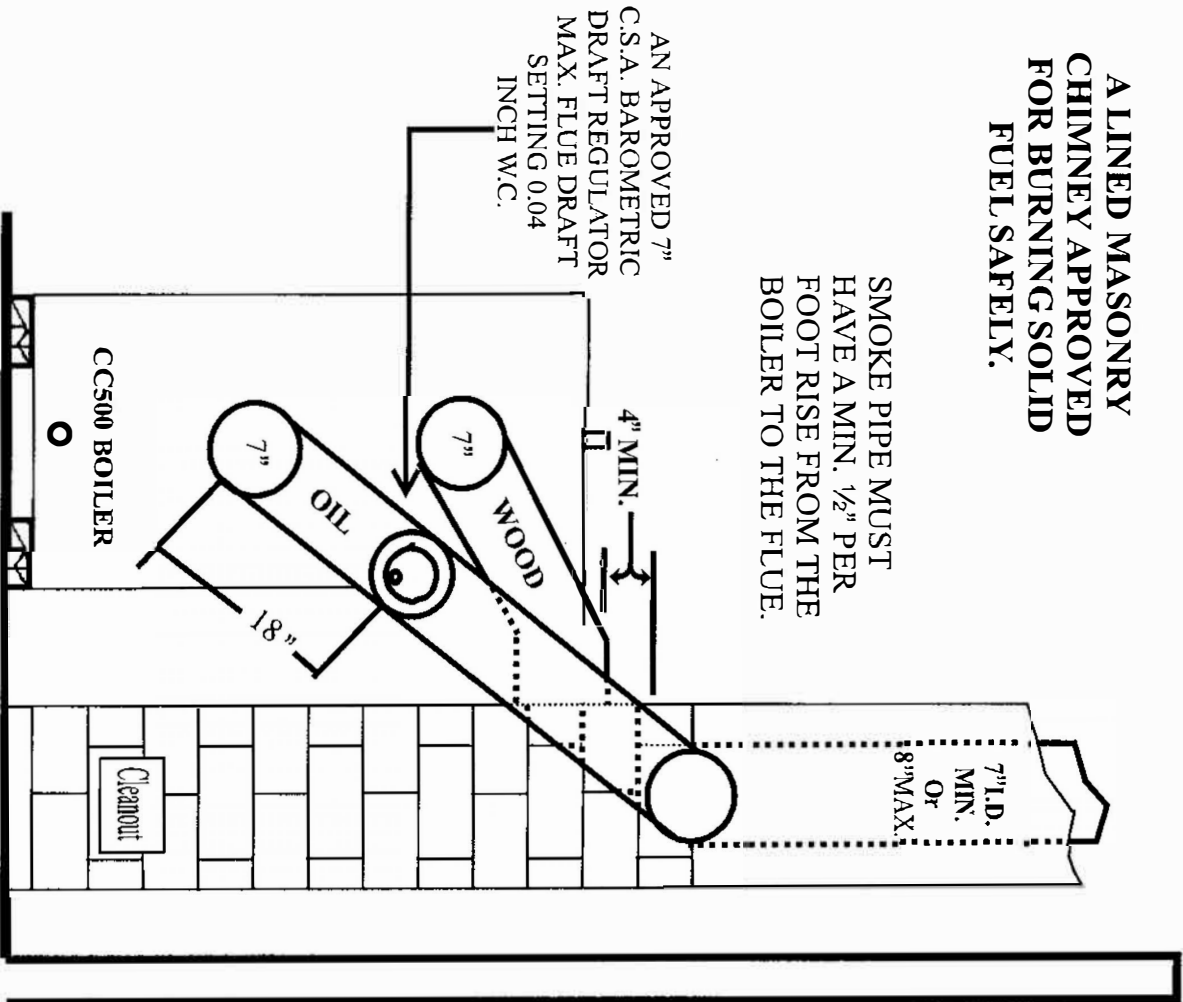

**FACTORY BUILT
CHIMNEY APPROVED
FOR SOLID FUELS**

SMOKE PIPE MUST
HAVE A MIN. 1/2" PER
FOOT RISE FROM THE
BOILER TO THE FLUE.

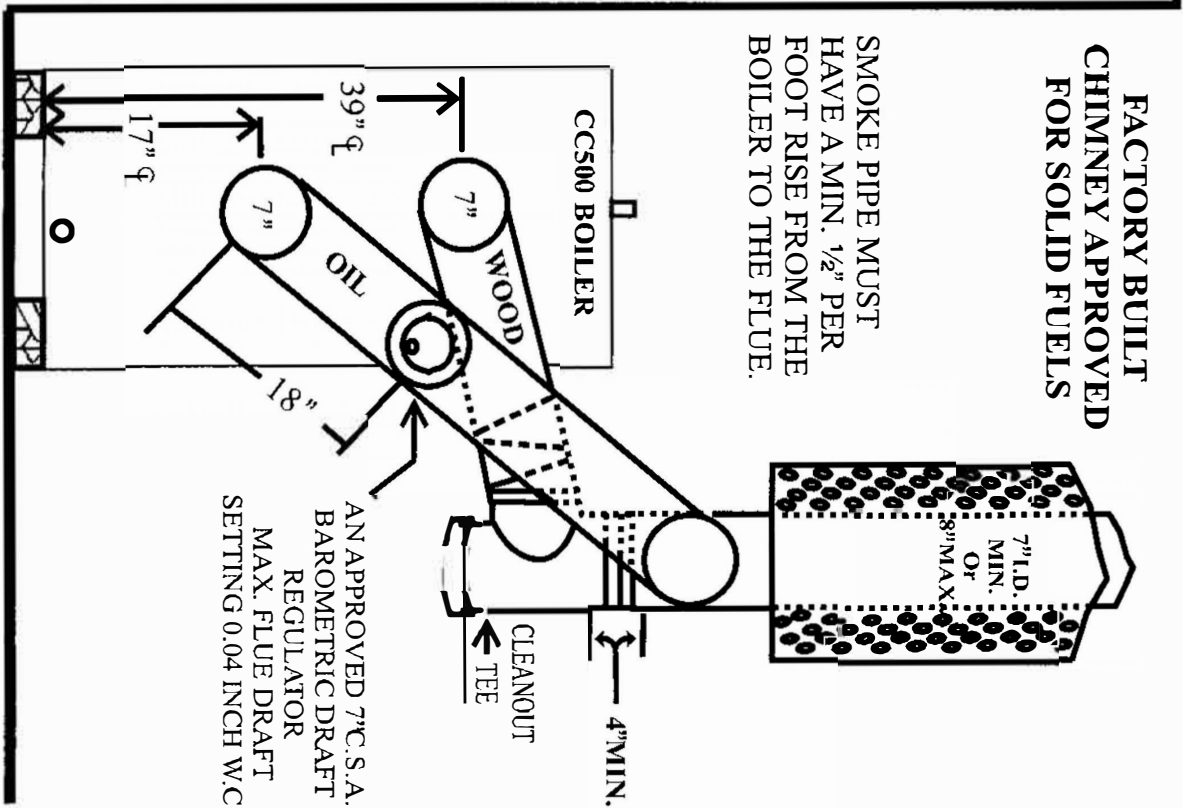

1. LOADING DOOR FOR WOOD
2. INNER DOOR SHIELD
3. WOOD FLUE BAFFLE
(ORDER # CC616)
4. SMOKE PIPE - WOOD-7 $\frac{1}{2}$ " I.D.
5. DOMESTIC HOT WATER COIL X 2
(ORDER # CC552)
6. OIL CHAMBER ACCESS PANEL
(ORDER # CC539)
GASKET
(ORDER # CC603)
7. SIGHT PORT DOOR
(ORDER # CC592)
GASKET
(ORDER # CC593)
8. OIL BURNER
9. OIL COMBUSTION CHAMBER
(ORDER # CC598)
10. STEEL COMBUSTION BAFFLE
(ORDER # CC597)
11. SMOKE PIPE - OIL-7 $\frac{1}{2}$ " I.D.
12. OIL BAFFLE SPACER
(ORDER # CC604)
13. COMBUSTION CHAMBER
SUPPORT ASSEMBLY
(ORDER # CC636)
14. STAINLESS COMBUSTION
BAFFLE
(ORDER # CC533)
15. OIL FLUE BAFFLE
(ORDER # CC535)
16. COIL GASKET
(ORDER # CC586)

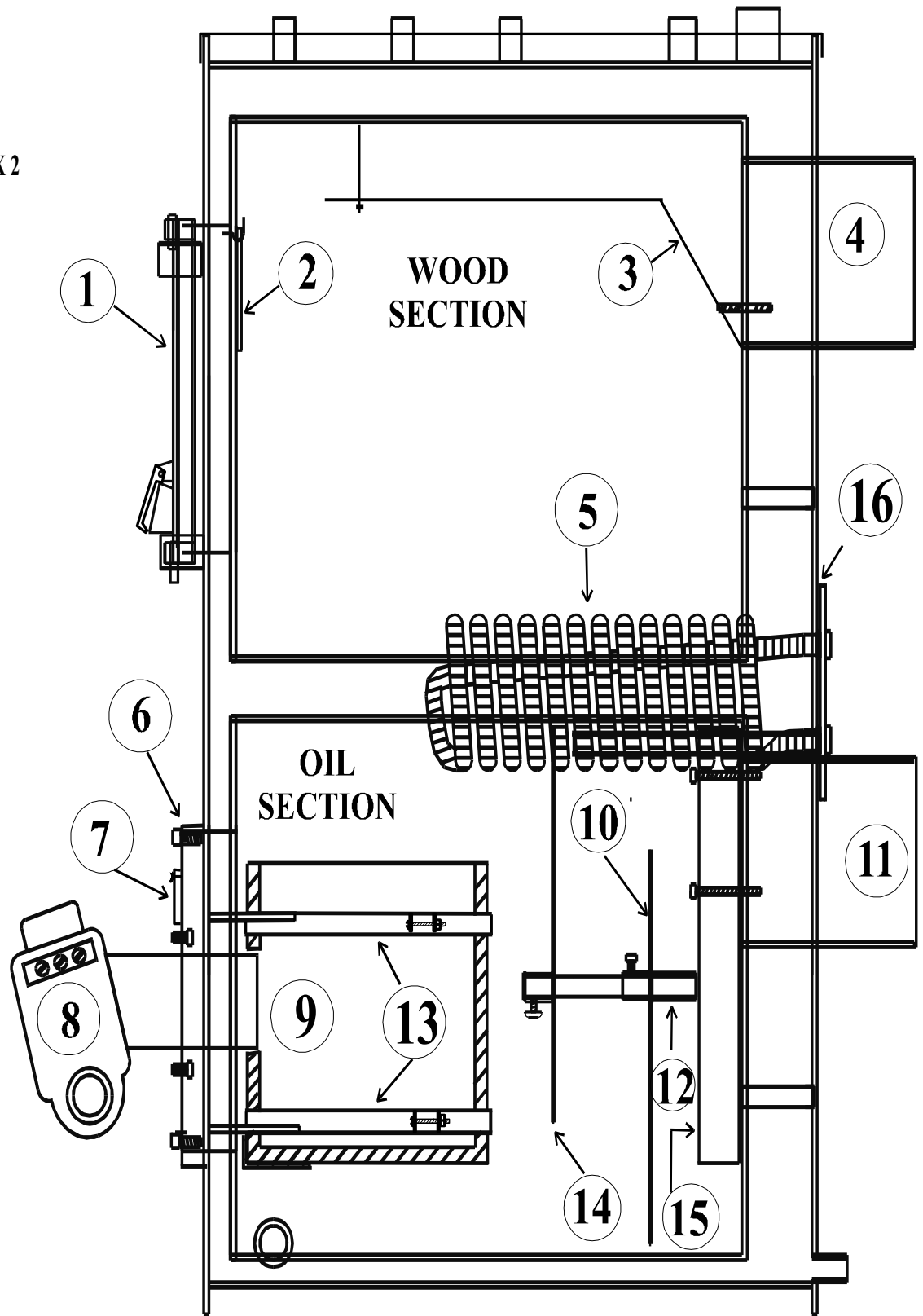

CC500 PIPING & WIRING LAYOUT

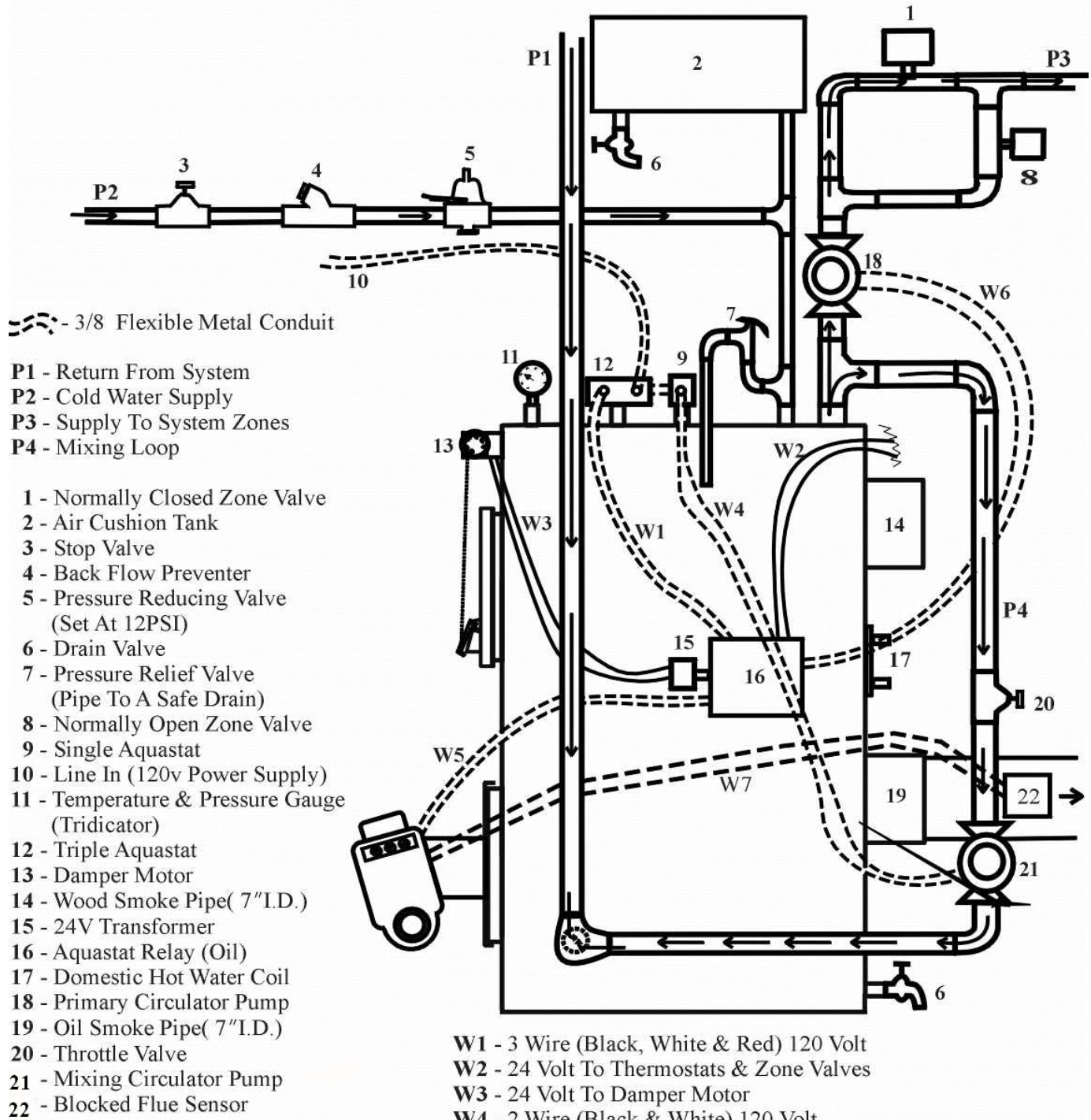

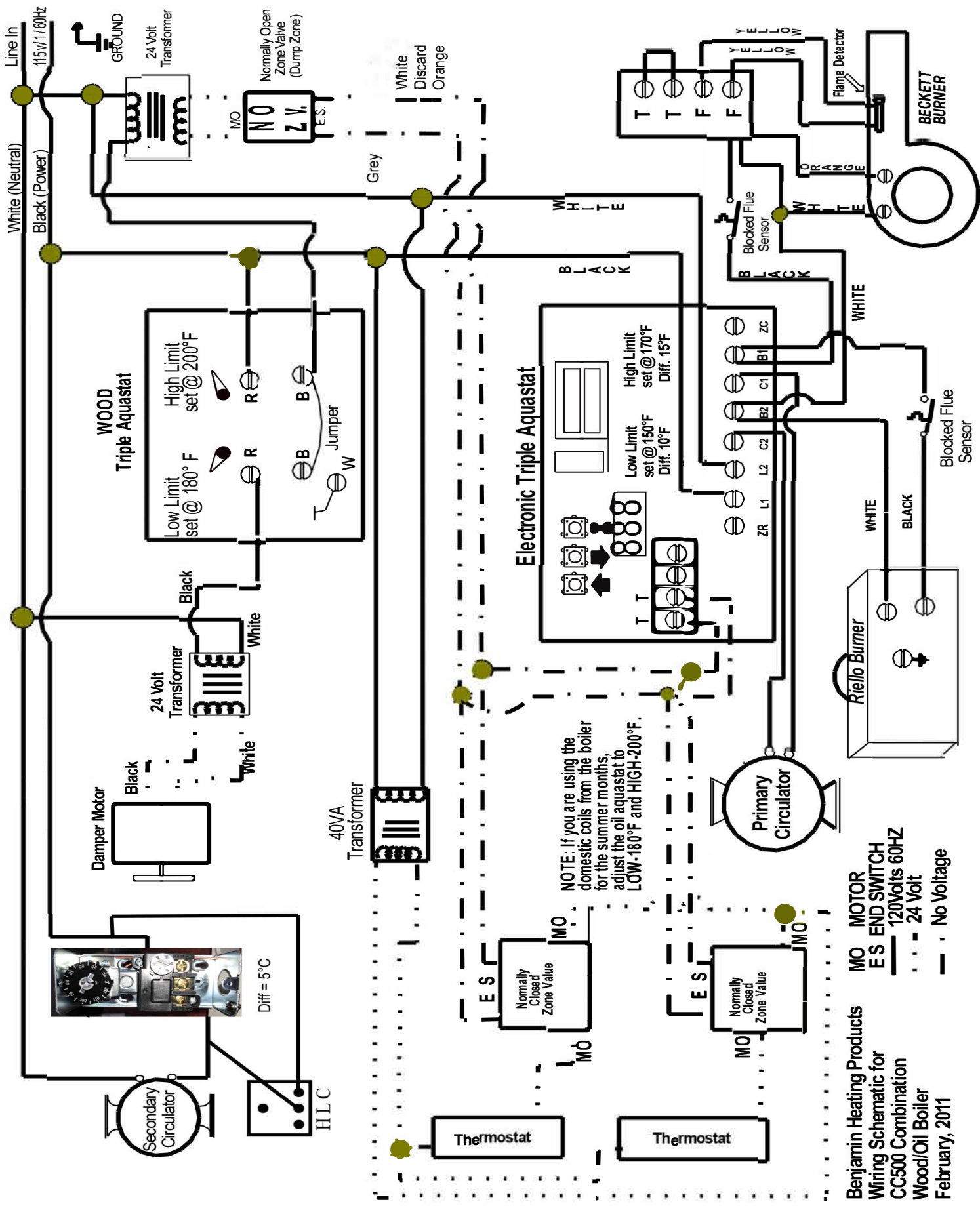

Benjamin Heating Products
 Wiring Schematic for
 CCS500 Combination
 Wood/Oil Boiler
 February, 2011

DOMESTIC HOT WATER SUGGESTED PLUMBING FOR COILS

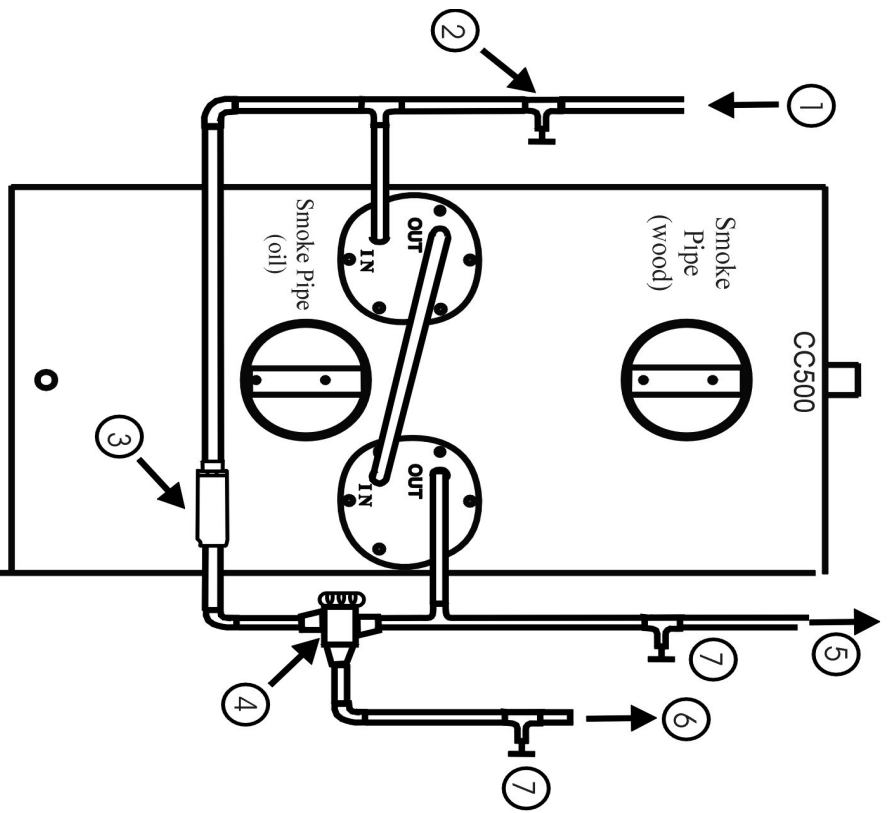

1. Cold Water Inlet
2. Shut Off Valve
3. Check Valve
4. Tempering Valve (8" below the coil Outlet)
5. Hot Water To Appliances
6. 120°F Max. Tempered Water to Fixtures
7. Throttle Flow Valve

MIXING CIRCULATOR PLUMBING

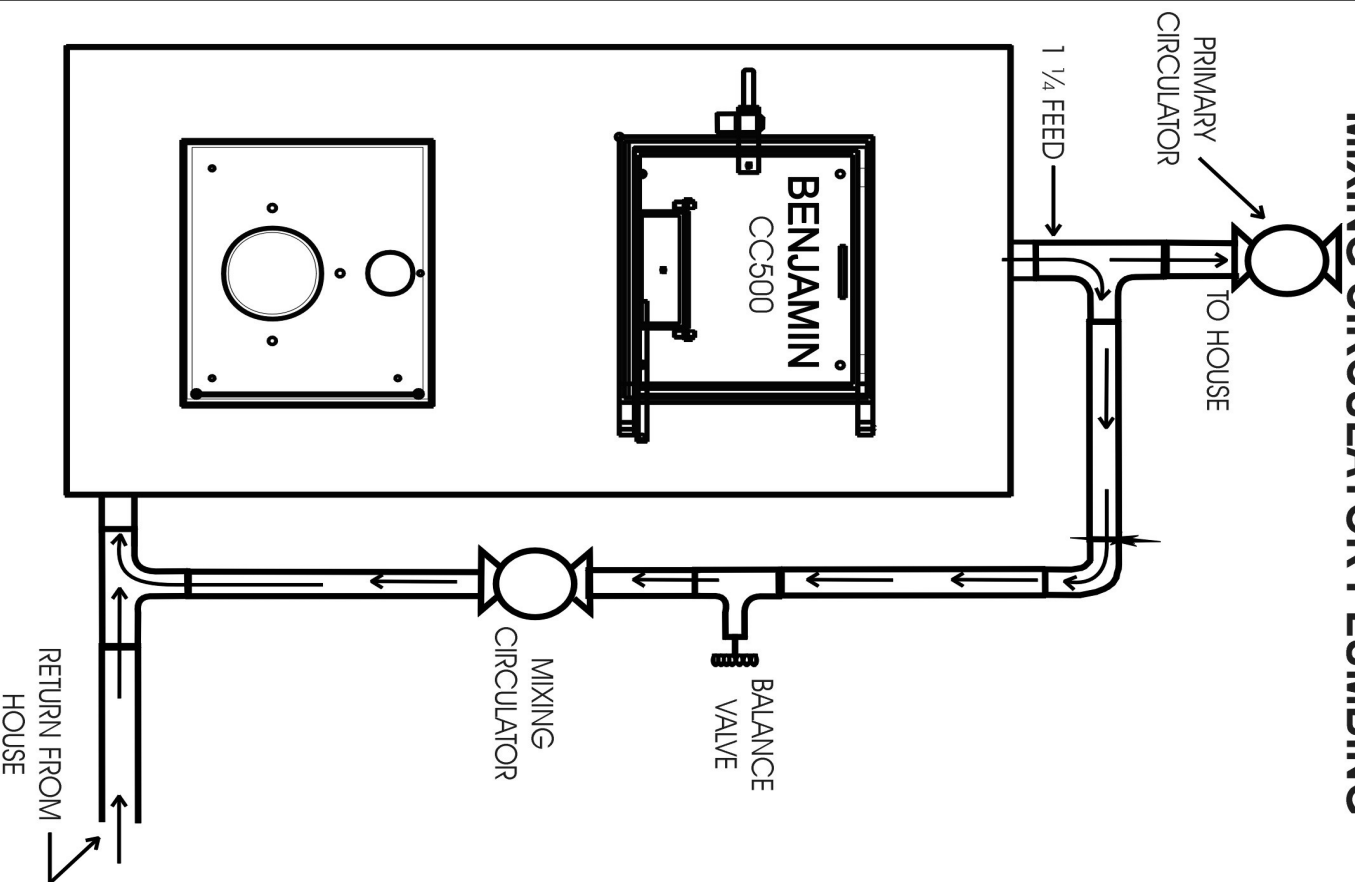



A division of W.R. BENJAMIN PRODUCTS LIMITED

P.O. Box 2079, Springhill, Nova Scotia

Canada B0M 1X0

Phone: (902) 597-3796

Fax: (902) 597-3797

E-mail: info@benjaminheating.com

Web site: www.benjaminheating.com